

Screw On Hinge 980440 2pcs

Installation Drawings

Acrew-on-hinge, flat, installation drawing of hinge, art. no. 248340
 Set no. 980440 2pcs. hinge art. no: 248340 with cover cap
 (height - and side adjustable)

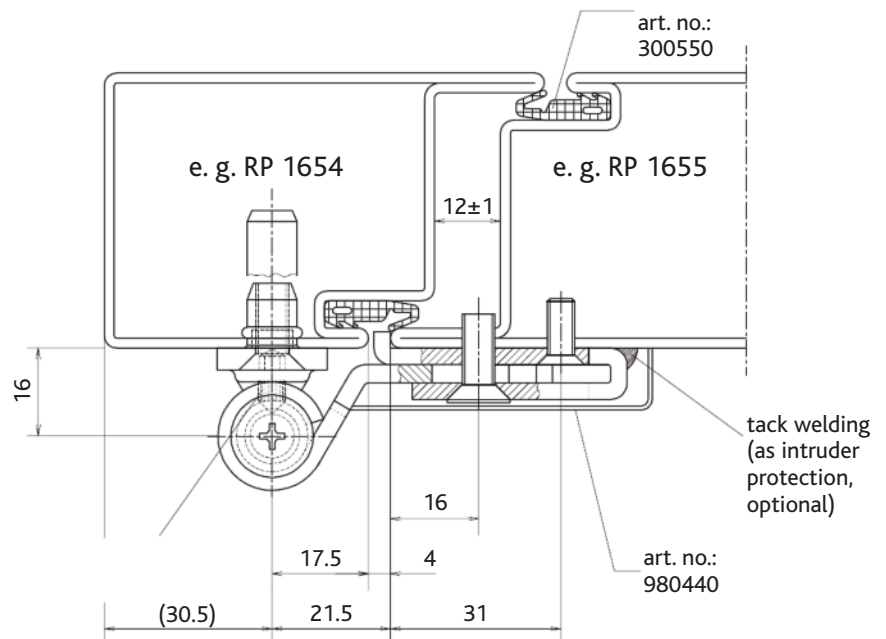
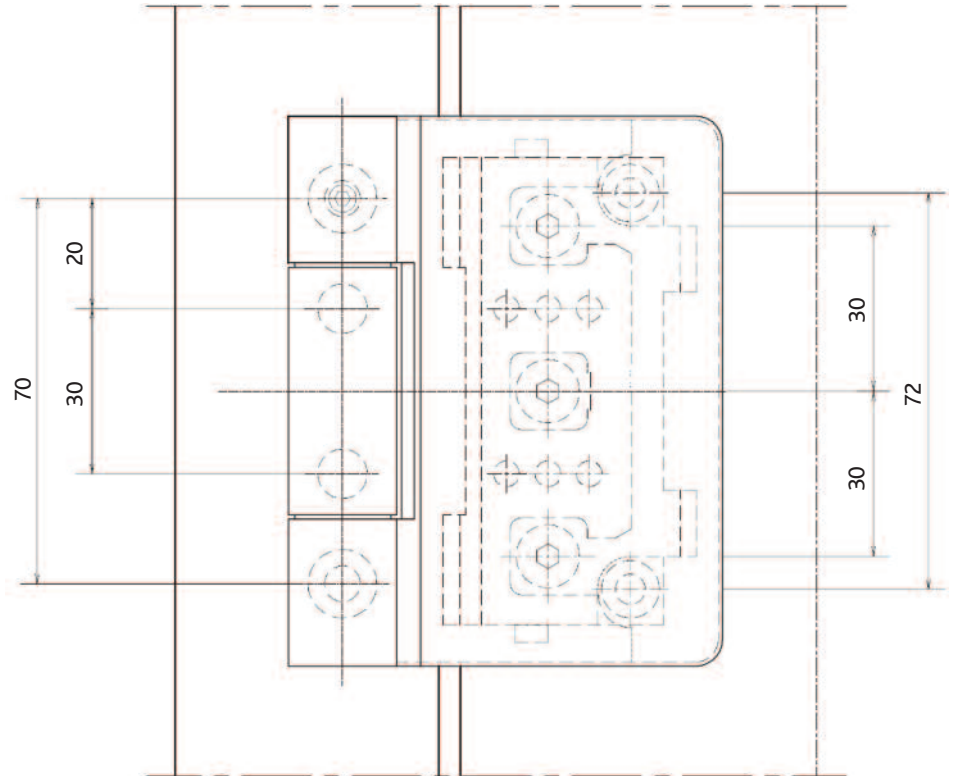
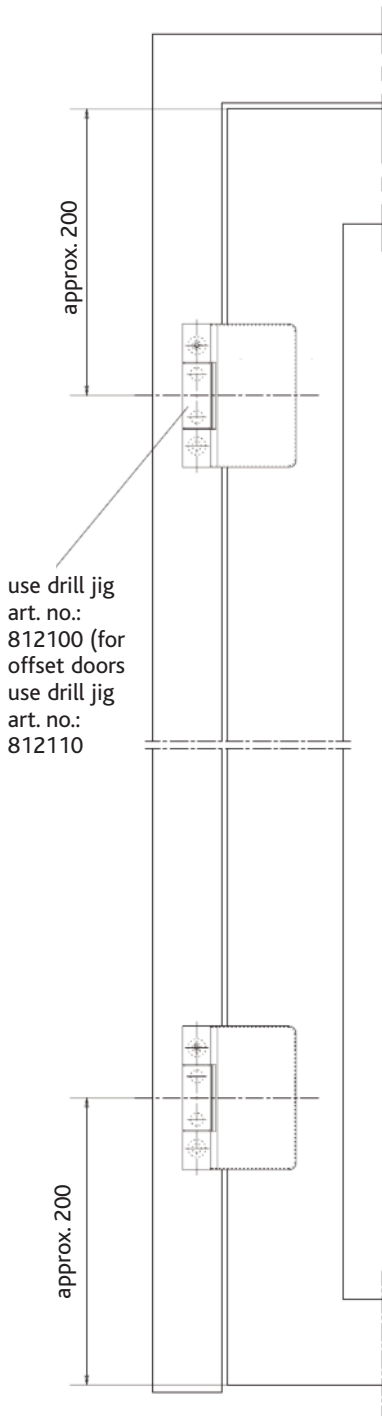

Assembly Instructions

- bring cover frame and leaf profile in correct position (attention) to leaf rebate dimensions) and drill with drill jig RP accessories art. no. 812 100 or 812 110
- press bush [4] into frame hinge receptacle [3]
- press distance bushes [7] into leaf part [6]
- insert 2 countersunk blind rivet nuts M6 [1] into outside drilled holes at cover frame profile
- line frame hinge receptacle [3] with supporting plates [2] if needed and fix with trilobular countersunk screws M6x20 [5] (install with supporting plate [16] for rest-on door leaves.
- screw on frame hinge receptacle [11] with two trilobular countersunk screws M5x12 [12]
- insert leaf part [6] into leaf hinge receptacle [11] so that the drilled holes in the leaf part [6] and in the hinge receptacle [11] are aligned (zero position). Clamp both parts and insert and tighten 3 thread-forming trilobular countersunk screws M6x14 [13]
- drill cross slots of countersunk crews M5x12 [12] for intrusion protection of leaf hinge receptacle [11] (alternatively tack-weld in strap zone, see*)
- join frame and leaf connection and insert push-in axis [8] from above (the safety nose at the pin head must engage in the roll hole), fix push-in axis [8] with pin screw [9] from bottom.
- for intrusion protection from top back insert and tighten thread pin M5x6 [10] at frame part [6] while leaf is open.
- assemble door and complete by loosening the screws [13], the leaf can be adjusted. tighten screws after adjusting. After that one of the 6 free drilled holes has to be drilled with 15 mm and a centering pin [14] must be hit in as sliding safety. (the door can be readjusted several times if needed).
- dip cover cap [15] onto top edge of leaf part [6].

Screw-on hinge set fits for all RP smoke protection door systems

Steel, flat, with cover cap, safe height adjustable (+/- 4mm) side adjustable (+/- 3mm) galvanised and chromatic (1 PU = 2 hinges: DIN ri / le) type test with 2 hinges: door leaf weight max. 130 kg

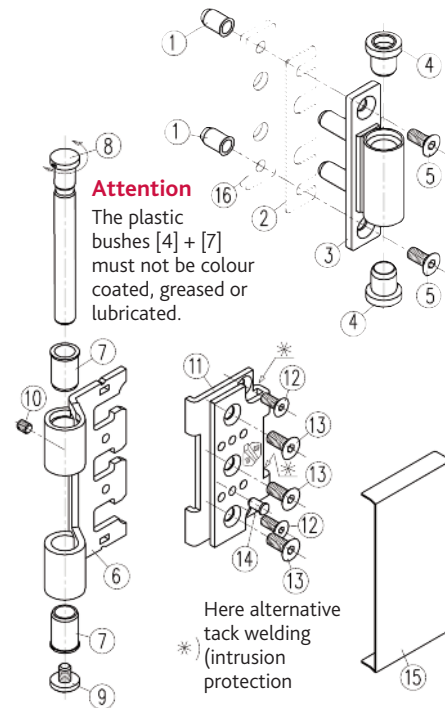

pos.	description	pieces
1	countersunk blind rivet nut M6	2
2	supportin plate 1mm (tolerance compensation)	2
3	frame hinge receptacle	2
4	bush (plastic)	2
5	trilobular countersunk screw M6x20	2
16	for RP-hermetic 50 (offset doors) supporting plate 4mm	1

pos.	description	pieces
6	leaf part	1
7	distance bush (plastic)	2
8	knock-out spindle	1
9	pin screw	1
10	thread pin M5x6	2
11	hinge receptacle leaf	1
12	trilobular countersunk screw M5x12	2
13	trilobular countersunk screw M6x14	3
14	centering pin	2
15	cover cap	1

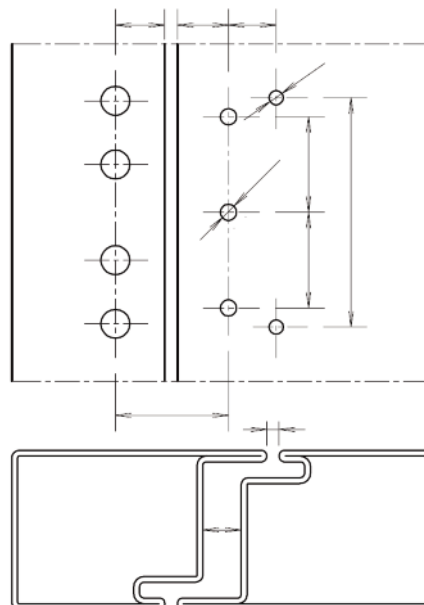

- Support door leaf
- Remove cover cap [15] by pulling to side
- Remove centering pin [14] with tongs
- Loosen countersunk screw [13]
- Adjust leaf
- Retighten screws [13]
- Drill new hole with 15 mm for centering pin [14], resecure leaf by setting new pin
- Clip on cover cap [15]

To contact us or for more information please see below

Tel: 0114 234 5288 Fax: 0114 234 1643

ASD Architectural, 901 Herries Road, Hillsborough, Sheffield S6 1QH

rp@asdmetservices.co.uk www.asdarchitectural.com

